



WOODWORKING

Project Guide

Level 3



CANADA
4-H Alberta

The 4-H Motto

“Learn To Do By Doing”

The 4-H Pledge

I pledge:

My **head** to clearer thinking,

My **heart** to greater loyalty,

My **hands** to larger service,

My **health** to better living,

For my club, my community,

my country, and my world.

Published by 4-H Alberta for the 4-H community.

For more information or to find other helpful resources,
please visit the 4-H Alberta website at www.4hab.com.

TABLE OF CONTENTS

Level Three Objectives	1
Achievement Day Requirements	3
Additional Resources	5
Safety in the Woodworking Project	7
Safety Contract (to be signed).....	9
Forestry Industry	11
Drafting, Drawing & Dimensioning.....	13
Joinery	15
Power Tools.....	19
Clamping & Gluing	25
Additional Hand Tools	29
Sharpening of Tools	31
Woodworking Tips	33
Things to Make.....	35
Members: I Can Checklist.....	57
Evaluation	61



LEVEL THREE OBJECTIVES

Members will be able to:

1. Work safely with wood to produce personal projects made of wood.
2. Identify and use woodworking tools and supplies in a safe manner.
3. Challenge themselves with a variety of projects and varying levels of complexity of tasks in woodworking.
4. Work cooperatively with others in a workshop environment.
5. Develop skill in decision making, leadership, problem-solving, finances and communication.



ACHIEVEMENT REQUIREMENTS

Level Three:

1. Completed Record Book
2. At least two completed projects which use different types of joints and which required the use of power tools studied in this project.
3. Plans drawn by the member for a personal project. Cardboard model of intended project.
4. Item made by the member which required the use of a router.
5. Display of tools sharpened by the member. (Chisels, screwdrivers etc.)



ADDITIONAL RESOURCES

People

- local woodworkers
- teachers
- family members
- other 4-H members or leaders

Places, Events and Organizations

- local woodworking clubs
- exhibitions and fairs that have a woodworking class
- colleges that offer woodworking, design, or similar courses
- displays
- museums sometimes have displays with wooden articles

Things

- books or magazines
 - *Canadian Home Workshop*
 - *Woodworkers Journal*
 - *Wood Magazine*
 - *American Woodworker*
- furniture
- buildings featuring wood

Web sites

www.thewoodcrafter.net
www.leevalleytools.com
www.woodworkershop.com
www.intheworkshop.com
www.uniqueprojects.com
www.am-wood.com (Amateur Woodworker)
www.northpolechristmas.com
www.tdc.ca/ewebster.htm
www.feesa.ab.ca
www.woodlinks.com

SAFETY IN THE **WOODWORKING PROJECT**

List as many preventative actions as you can for the following risks:

AT RISK	RISK	PREVENTATIVE ACTION
EYES	Flying chips Dust Splashing finishes Splinters from breaking tools Fumes Compressed air used improperly	
EARS	Exposure to loud noises	
LUNGS	Exposure to very tiny dust particles (less than 10 microns) Exposure to fumes from finishes Inadequate ventilation	
SKIN, FINGERS, LIMBS, HANDS AND FEET	Punctures, rips from tools and rough wood. Crushing Pinching Exposure to chemical finishes Abrasions Burns from hot tools	
BACK	Lifting too much Falls from tripping over materials Turning incorrectly Lifting incorrectly	

*You must purchase your own personal safety equipment for the 4-H woodworking project.
Eye protection must be worn.*



Who does an unsafe worker affect?

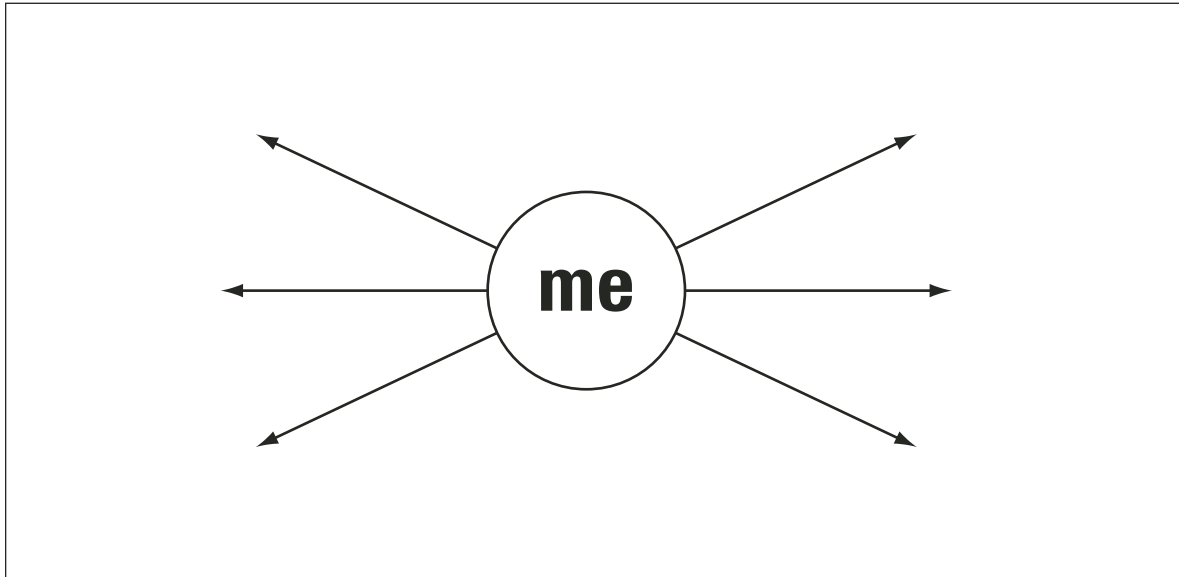

Safety Steps

1. Name the risks
2. Safeguard the work area.
3. Wear necessary protective equipment.
4. Use the right tools.
5. Follow correct procedure.
6. Monitor work habits.
7. Correct as necessary.

Ensure all helpers follow safe procedures

- Where are the First Aid kits kept at your 4-H meetings?
- Where are all the First Aid kits at home?
- Who has First Aid training in your 4-H club?
- Who has First Aid training in your family?
- What phone number do you call for emergency help?
- What are the directions to drive to your meeting place? (In case you ever had to give them to emergency people)
- What are the directions to get to your home? (In case you ever had to call emergency people)
Post these by all the phones in your home or shop.

Contents for a Basic First Aid Kit

A variety of bandages; antiseptic; tweezers; First Aid booklet; cotton swabs; sterile gauze; First Aid tape; needles (to get out slivers); eye drops.

SAFETY CONTRACT

I Will:

- identify risks of activities
- take actions to eliminate or reduce risk
- ask for help when needed
- select the correct tools, equipment and materials for activity
- watch for and allow for closeness to other people
- stop work and move back when ask to
- exit work area on command (in case of emergency)
- return tools and supplies to storage after use
- follow safe disposal procedure
- dress appropriately for club activities
- share responsibility for safety in the club

Member

Parent

Leader

Date

FORESTRY INDUSTRY

Objectives

Members will be able to:

- identify forestry as one of Alberta's major industries and employers
- trace the route of wood products from wood lot to consumer
- name at least five careers linked to forestry and the preparation for that career
- list sources of information on the forestry industry

Facts On Forestry

- Canada is the world's largest exporter of wood and wood products
- forest products were one of the largest contributors to the surplus balance of trade for Canada in 2001
- Canada has 10% of the world's forests
- 60% of Alberta is covered by forest
- The forestry sector provides approximately 54,000 jobs in Alberta
- The forestry sector generates \$1.6 billion in household income in Alberta
- The forestry sector is the primary industry in at least 45 communities in Alberta

Forestry Related Career Opportunities

- Research and development
- Logging
- Trucking and other services
- Manufacturing of forestry products
- Environmental protection
- Fire protection

Training and Education Opportunities re: Forestry

- University of Alberta – Faculty of Agriculture and Forestry
- Junior Forest Rangers Program – Alberta Sustainable Resource Development
- NAFA (National Aboriginal Forestry Association)
- Alberta Forestry Advanced Management Institute (Hinton)
- Silviculture Institute of British Columbia
- Lakehead University, Thunder Bay

Visit www.woodlinks.com for additional information on forestry careers.

DRAFTING, DRAWING & DIMENSIONING

Isometric Drawings

- Shows what an object would look like from one side and a bit below your eyes (like looking down at something sitting on a table)
- Is helpful for getting an idea of what the project will look like
- Helps indicate what type of materials will be needed

Sketch an example of an isometric drawing here.

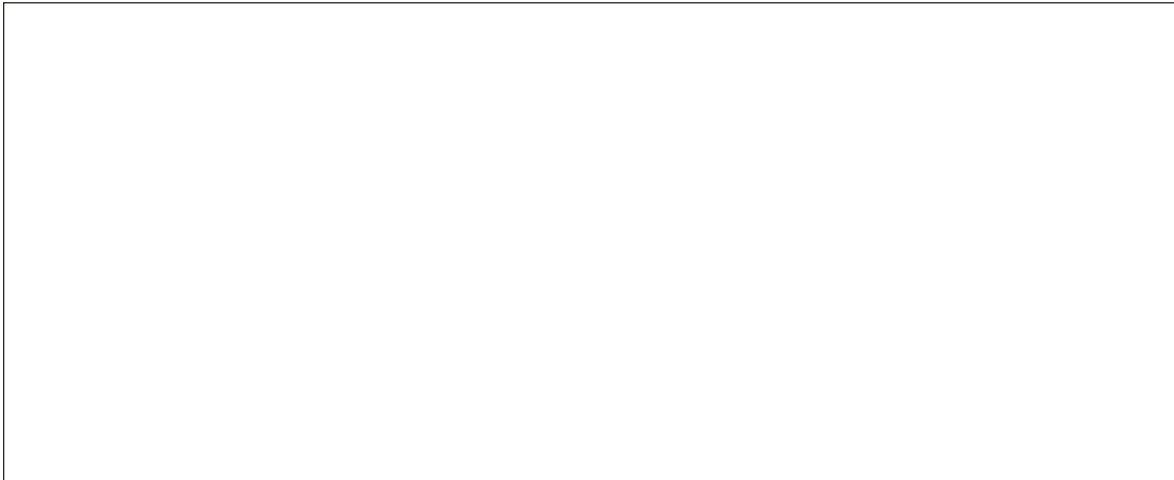

Orthographic Drawing

- This type of drawing splits the object into different views: the top, the sides and the front
- An orthographic drawing is drawn accurately and to scale*

** to scale means that each measurement on paper is in proportion to a measurement in real life. e.g. One cm on paper represents 10 cm in real life.*

Sketch an example of an orthographic drawing here.

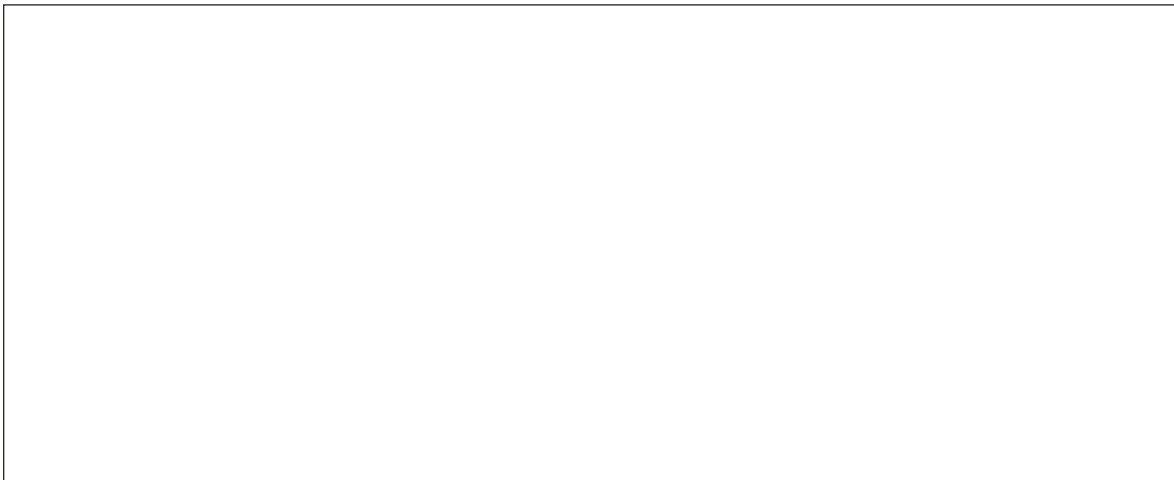

Sources of Plans, Patterns

Web sites

www.thewoodcrafter.net
www.leevalleytools.com
www.woodworkershop.com
www.intheworkshop.com

Books

Check out the library!

Your Imagination

And, best of all your own head!

Someday you will need a special item for a particular spot. You may look in stores or catalogues to see if the right thing is out there for sale. Then it hits you! I can make this myself! Here's how to do it.

Custom Designs by Me

1. Decide what you want this project to do for you. What are the requirements of the project?
Let's say you want to build a shelf for your school locker. There will be size limitations. It will have to be a certain strength. Do you want it to be adjustable, so you can move it up and down? Will you have to assemble it after you have put the pieces in the locker or can you preassemble it at home? Do you plan to store heavy or light objects on this shelf?
2. Take measurements of the space to be occupied by the project. Measure your locker door. Measure the inside of the locker.
3. Make both isometric and orthographic drawings of the project. This step helps you think through the building and use of the item.
4. Make a paper or cardboard model of the project. Test it in the space that you intend to use the actual article. Many design problems are detected at this stage! It is a lot cheaper to discover a mistake with a paper model than it is with an expensive wood object!
5. Make any necessary design changes. Repeat your test.
6. Transfer your pattern to wood. Proceed with building the real article.
7. Install, use and appreciate your custom designed project.
8. Take a picture for your record book!



JOINERY

Dovetail

A variety of joints have been designed and used by woodworkers. They vary in procedure, strength, appearance and skill required to make them. Some of the techniques used by pioneers with crude tools are still holding today!



When buying wooden furniture, the quality of joints used indicates the strength and quality of the furniture. The better quality the joints, the more expensive the furniture. You will make at least two different types of joints for this project.

Different joints are suitable for different purposes. Choose the correct joint for your project. Then, construct it properly. Glue and clamp it securely.

Butt Joint

This joint is the easiest and also the weakest. It is usually the first joint most of us make. You might see this kind of joint in a bird house or feeder, because those items do not need extremely strong joints. Sometimes the butt joint is reinforced by dowels or corner braces.

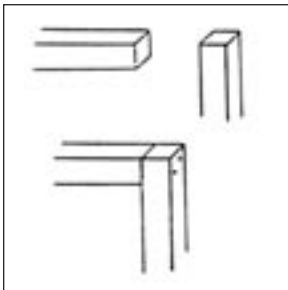

Examples of butt joints in woodworking: _____

Mitre Joint

The mitre is a type of butt joint. The wood is cut at a precise angle using a mitre saw and mitre box.

It looks better than a butt joint and is a bit stronger. It can be tricky to clamp.

Picture frames and door frames often use this type of joint because it is a good way to join ornamental wood. You will notice that picture frames are pinned or reinforced at the corners for extra support.

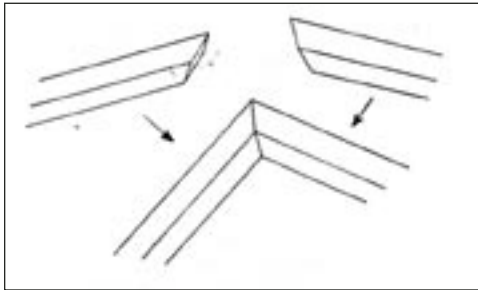

Examples of mitre joints in woodworking: _____

Rabbet Joint

This type of joint is often used for drawer fronts in cabinet work. A cut is made at the end of a board so it will fit into another one.

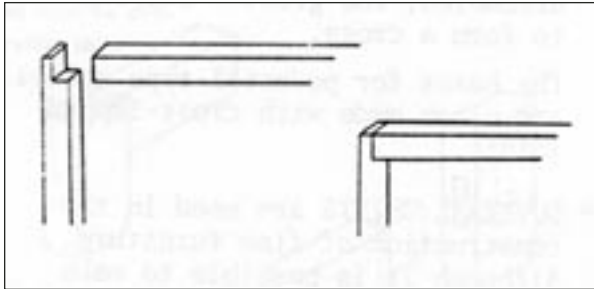

Examples of rabbet joints in woodworking: _____

Dado Joint

A dado joint is like a rabbet joint, except that the joint is made in the middle part of the board, not the end. This is a strong joint, because there is a lot of surface contact. Dado joints are used to make slots for shelves and other spots needing good support.

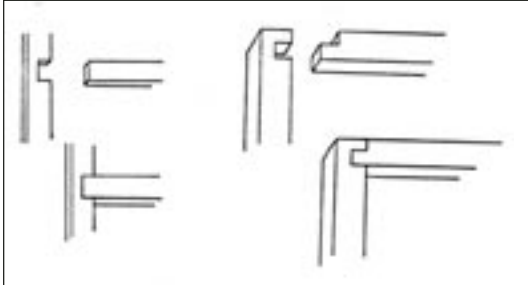

Examples of dado joints in woodworking: _____

Dowelled Joint

Pioneers used to make their own dowels to avoid having to buy nails. Dowels are hardwood pins that come in a variety of sizes. Holes are drilled and lined up to fit dowels tightly.

A dowelled joint may be any joint that is reinforced with dowels (short, round pegs). Butt joints are the most frequently dowelled joint. Most table legs are attached to the frame with dowels.

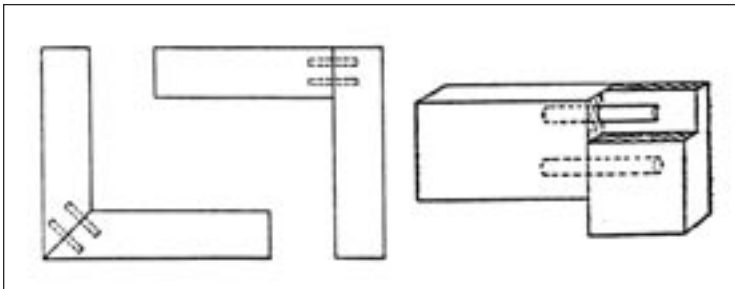

Examples of dowelled joints in woodworking: _____

Sometimes dowels snap off at a point of stress. (This is why people tell us not to tip our chairs.) The old dowel has to be removed (with a drill or careful chiselling), the hole cleaned and reglued. The replacement dowel is sometimes a bit larger than the original.

The types of joints I like the appearance of:

The types of joints I appreciate for their strength:

The types of joints I am going to practice making:

POWER TOOLS

Router

This is a great tool that can accomplish all kinds of decorative and functional work. It is designed to cut across and along wood edges. Examples of router work include table edges, signs, grooves and clean cut holes.

Routers spin at speeds up to 24,000 revolutions per minute (RPM). Compare that to a drills 3,000 RPM! It is very important to secure the bit before starting up the router.

As with any tool, do not force a router. Forcing a router can ruin the bit and damage the motor. Especially when working with hard wood, it is often necessary to take more than one pass to remove the amount of wood you want.

Routers use interchangeable bits so that you can make a variety of patterns in the wood. These bits are very hard, very precise and usually very expensive! Cheap bits are just that. Cheap.

When choosing bits, think about all the uses you will have for that design. Most woodworkers start out with the edge round and a straight bit.



Practice using a router with the bits available to you. Which patterns do you like? Which patterns would work for your project?

Practice Using a Router – Name Plate

Materials

- always use eye or face protection
- a router and a straight bit, 2mm or 3mm
- wood, 2cm by 20cm by 50cm
- pencil
- clamp
- stencils (optional)

Procedure

1. Check that the bit is secure and set to a 2mm or 3mm depth.
2. Print a name or word on the wood in letters so it suits the dimensions of the wood. You can make a sign that says shop, office, keys, Grand Poobah or whatever you like. If you wish, use stencils to outline the letters. Remember that the router will remove quite a bit of wood. Leave space between each letter.
3. Clamp the wood to a bench or place it in a vice with the top edge just above the vise edge.
4. Operating a heavy router is tiring. If you get tired, stop.
5. Hold the router over the board so that the bit is right over the first letter. The router should be tilted so that edge touches the board.
6. Start the router. Slowly lower the router into the letter space you want to dig out. Cut out the outline of the letter first, then go back and clean out the insides. Some people like to just outline the letters and not clean out the insides.
7. Paint or stain your letters and the wood around them. One technique used by campgrounds is to paint the letters one colour and paint the flat wood another colour with a roller.

Bandsaw

The bandsaw is an impressive stationary power tool. Its blade is a loop of steel with teeth on one edge. The blade is driven and held in place by two large wheels. The wheels and most of the blade are covered by metal shields. The blade runs through guides to keep it straight.

A bandsaw is something like a granddaddy jigsaw - it cuts straight or curved lines at a tremendous speed. The blade cuts in a continuous downward stroke at a high speed. It cannot tell the difference between fingers and wood, so watch your work!

To use the band saw, you push the wood slowly into the blade. Cut corners and tight turns slowly and carefully. If you put too much stress on the blade it can break. One way to tell you are stressing the blade, is that it starts to make a different sound. You can also smell the wood getting hot.

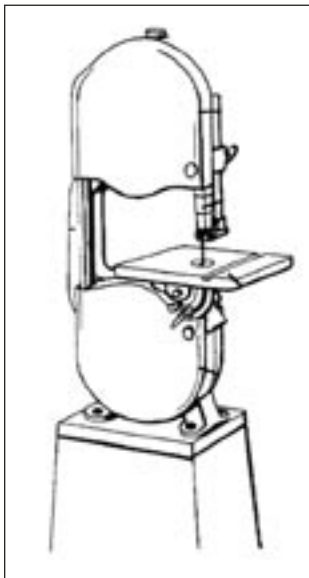

Drill Press

A drill press is a large stationary tool that operates at high speed. You bring the drill bit down to the wood with a downward pull of a lever. A drill press uses a variety of sizes of bits which need to be secured before use. Ensure that the key is removed before turning on the drill.

To ensure that the drill bit goes completely through the wood, raise or lower the drill table accordingly, and place a block of scrap wood under your project.

Always place a piece of scrap wood under your project. This protects the drill bit from hitting the table. It also prevents splintering on the back of the wood you are drilling.

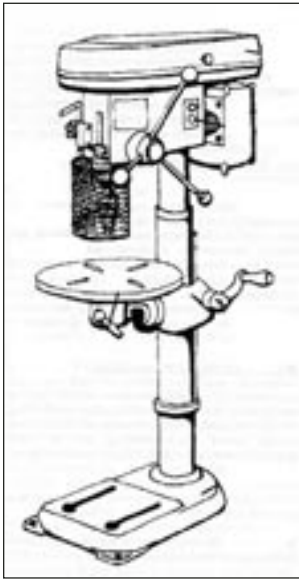

Safety Notes

1. Secure long hair. Do not wear loose clothes.
2. Before using the drill, always check to see that the last user removed the tightening key!
3. Hold the piece of wood you are working on securely. Otherwise, it might whirl around and whack you.

Stationary Belt Sander

The stationary belt sander is another versatile, powerful tool. Many stationary belt sanders also feature a disc sander attached to the front. The disc is helpful for squaring ends and sides of wood pieces. As this is a high speed machine, exercise great caution when using it. It can sand your fingers as fast as a piece of oak.

Use a stationary belt sander to square or round edges of wood parts. You can also shape smaller parts of wood with this machine.

When pushing wood into the belt, push slowly so you do not overtax the machine. When putting pressure on the belt, move the wood from side to side so the belt does not heat up or wear out on one spot.

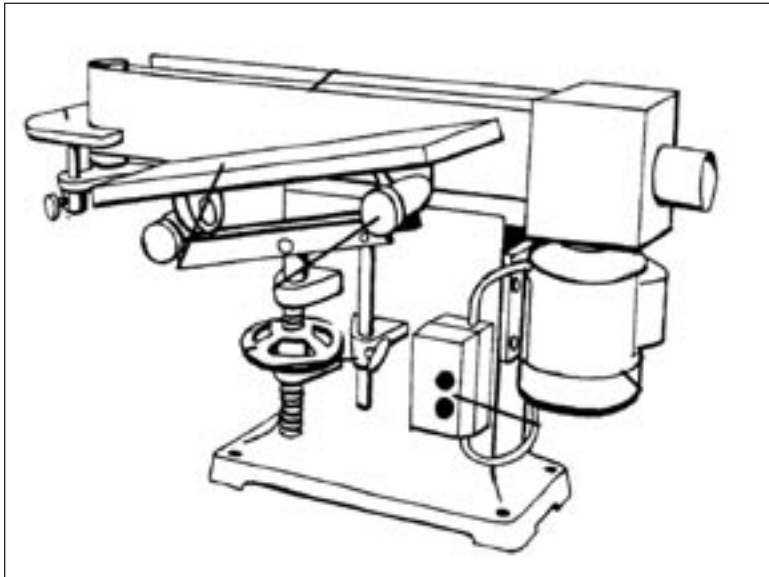

Radial Arm Saw

You will often see a radial arm saw on construction sites. It is used most often as a cut off saw (to cut wood to certain lengths). Radial arm saws can make exact duplicates of a cut, which makes it a very popular saw. The wood is held against the backstop with the left hand while the operator pulls the saw with the right hand.

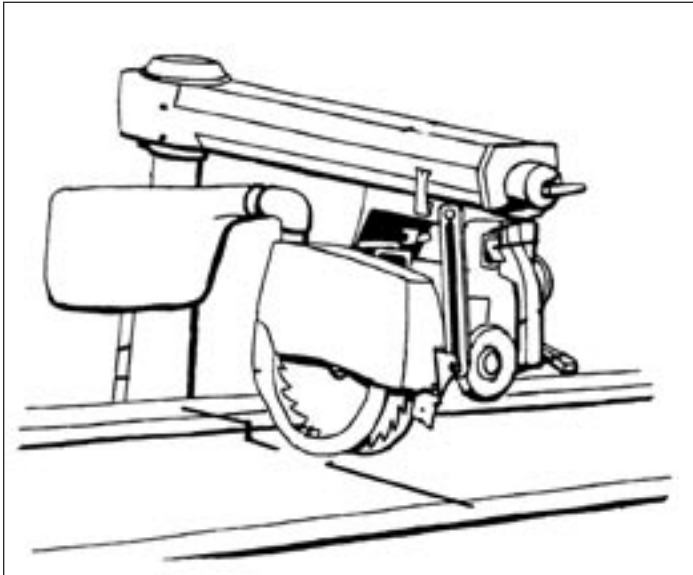

To Use the Radial Arm Saw

1. Wear safety goggles or a safety face shield. Ear muffs are also a good idea.
2. Keep appendages away from the blade. Use a push stick to push wood past the blade.
3. Put your wood against the backstop so that the cut line lines up roughly with the blade. Do not turn the saw on yet. Bring the saw blade down to touch the wood. Line the wood up so that the blade will cut on the waste side of the cut line. This is usually to the right of the line.
4. Slide the blade back. Hold the wood firmly. Turn the saw on. Draw the saw slowly and firmly towards yourself.
5. Turn off the saw. Admire the clean cut you have made with a radial arm saw.

Table Saw

This is a machine for the serious woodworker. It features a smooth steel surface and a blade that can be raised or lowered and tilted! On one side you will notice a rip fence which you use to cut boards to an exact width. The blade has a protective guard.

The push through device is also a mitre gauge which you can use to move wood into the blade at a specific angle. The angle can be set anywhere between 45 and 90 degrees.

The on/off switch should be in an easily accessible spot. The Off button is usually red. Always take note of the position of the Off or Kill button or switch button before you use a machine.

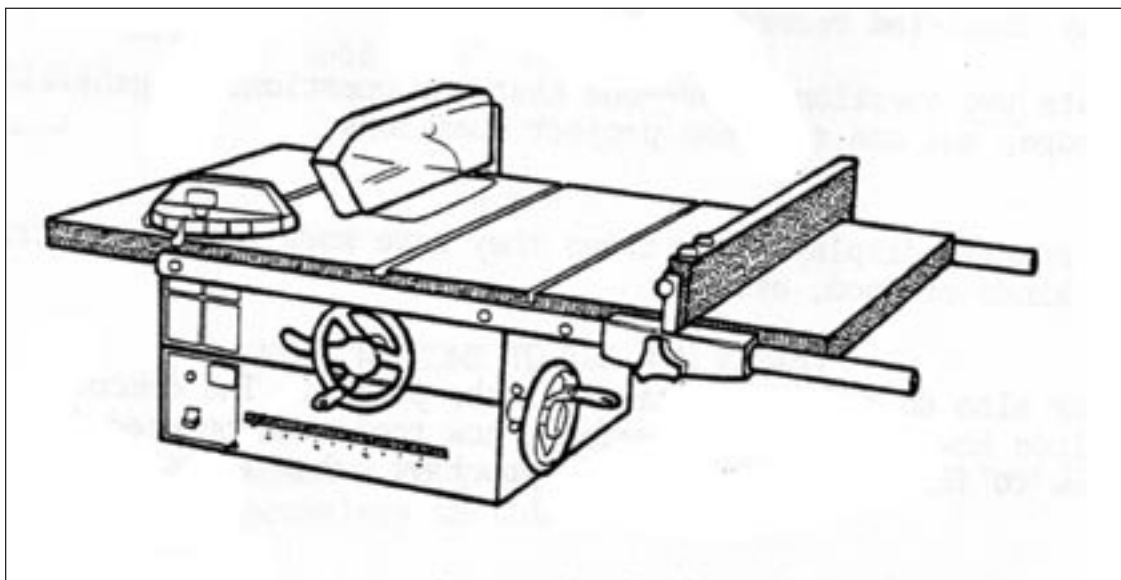

Using a Table Saw

1. Always wear goggles or a safety face shield. Use of a table saw in 4-H assumes adult supervision. Make sure sleeves are snug and not flapping.
2. If the table saw has a blade guard, use it.
3. Set the blade to a depth approximately 5 mm higher than the wood to be cut. Move the fence out of the way.
4. Set the mitre gauge to the cutting angle you want on the wood. Draw the gauge back so that the wood can be set against it without the wood hitting the blade.
5. Switch on the saw.
6. Hold the wood firmly against the mitre gauge with both hands. Slowly and steadily push the wood through the blade.
7. When the wood you are holding has passed the blade, slide it away from the blade and take it off the table.
8. Turn off the saw. Wait for the blade to stop before reaching for the cut part. It could touch the blade and get fired back at you.

Source: Saskatchewan 4-H

CLAMPING & GLUING

Epoxy glue

You have used white and yellow glues for other projects. White and yellow glues harden due to evaporation. When they harden, they shrink.

Epoxy glue does not shrink. Epoxy glue is a very strong glue that hardens due to chemical reaction. It is more expensive, so is used only when the project calls for it, such as joints where there are gaps. Epoxy glue fills up the gaps and then hardens to a very strong finish.

To use epoxy glue, it is necessary to mix two components together. Each glue will have its specific instructions on the container. Read them carefully and follow them completely.

When gluing wood, it is important that the wood be the same moisture content that it will be at time of use.

How to Glue

- select the appropriate glue
- prepare the project
- have the wood at the same approximate moisture level that it will be at time of use
- make sure all surfaces to be glued are clean and dry
- think through how you are going to clamp the project before applying the glue!
- have all the necessary equipment available
- apply glue to one or both surfaces (according to instructions)
- apply steady and uniform pressure with clamps
- wipe off excess glue
- allow glue to dry before removing clamps
- let the excess moisture at the joints (from the glue) evaporate before further machining. Let joints dry for several days.

Using Dowels

Dowels are used to fasten pieces of wood together and to strengthen joints. Dowels can be cut from dowel rods or purchased by the piece.

Dowel holes are cut with a drill press or with a hand drill, guided by a doweling jig.

What Diameter of Dowel? You should be able to insert the dry dowel into the dowel hole easily by hand. If it were too tight, the glue would be rubbed off as the dowel was inserted.

What Length of Dowel? Dowels are usually cut 1/4 inch shorter than the combined length of the two dowel holes. When you press the two pieces of wood together on the dowel, you do not want the dowel holding them apart!

What type of dowel? Choose between a plain dowel, a dowel with a longitudinal groove or a spiral grooved dowel. The grooves help the air trapped in the hole to escape and can help the glue to spread inside the hole, making for a stronger joint.

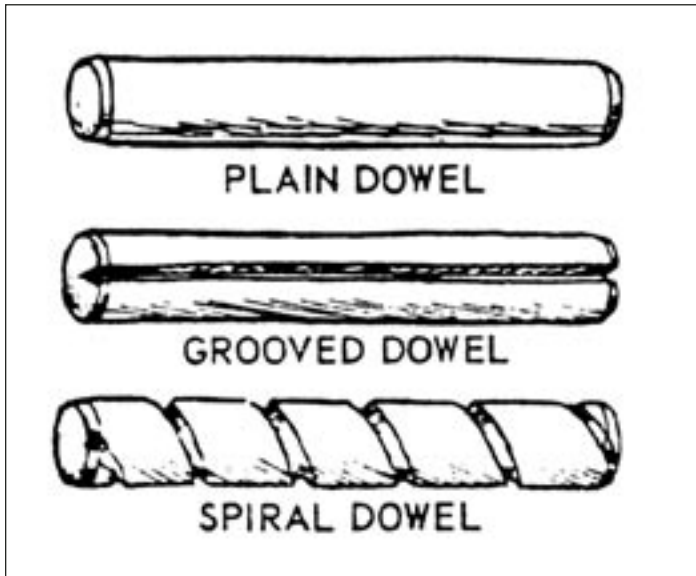

Do a dry run with the dowels in your project before applying glue!

Types of Clamps

C-Clamps

These are small c-shaped items which are used to hold two boards together for boring holes, gluing or making a saw guide. Tighten the screw to increase pressure. To prevent dents in the wood, put a piece of scrap wood between the clamp and the good wood.

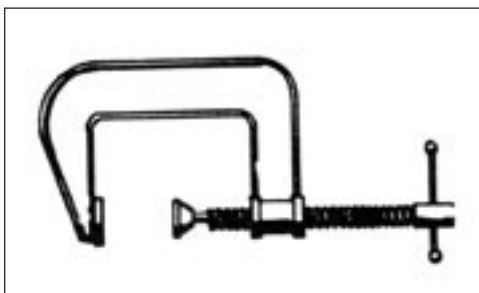

Handscrew Clamps

These clamps have two long parallel bolts which are adjusted separately. They are used for jobs that are too big for C-clamps. To adjust the pressure, screw the bolts in opposite directions.

Pipe Bar Clamps

These clamps come in a range of lengths. Adjust the clamp to fit the project by moving the adjustable stop back and forth along the bar. Increase pressure by turning the crank screw.

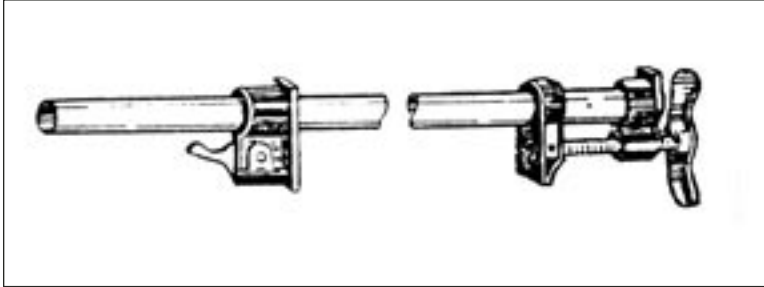

Adjustable Bar Clamp

This also called a cabinet clamp. It adjusts by turning the handle and can be used for the same purposes as the pipe bar clamp.

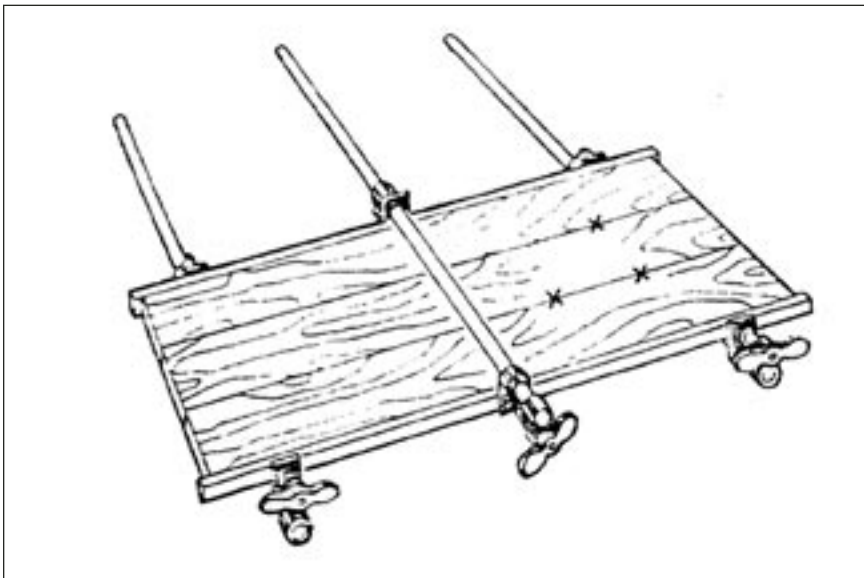

Clamping Tips

- keep clamps clean or you will be pressing grease and dirt into the wood fibres.
- protect wood surfaces by putting a piece of felt or scrap wood under the clamp
- use a piece of styrofoam against an irregular piece of wood when clamping. It will press into and hold the wood without marring.
- try pieces of inner tube as clamps for irregular pieces of wood

ADDITIONAL HAND TOOLS

Planes

Woodworkers use planes to smooth wood surfaces to reduce or eliminate the need for sanding. Sounds good to me!

- Plane with the grain, not against it or you will raise splinters.
- Always set a plane down on its side. This protects the blade.
- Make or buy a fabric sock for storing your plane.

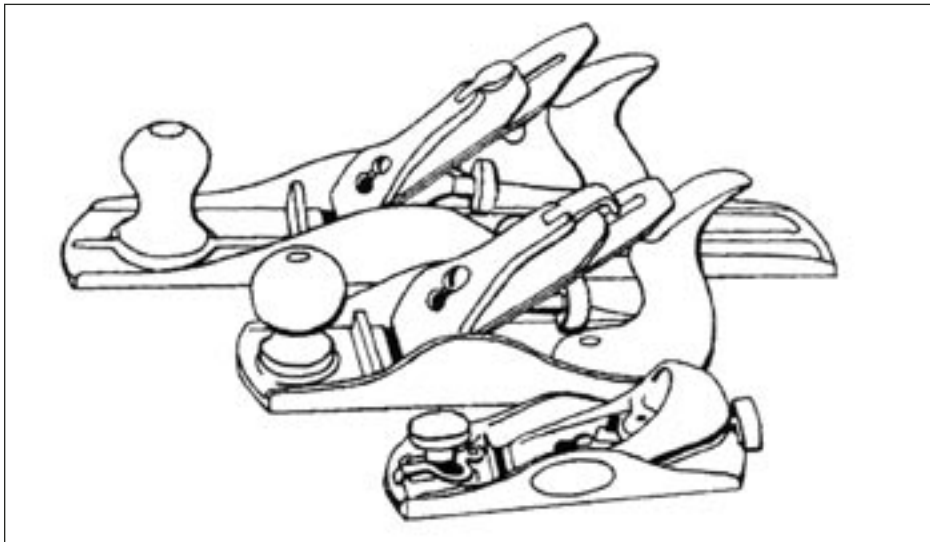

There are many kinds of planes available. Here are the most commonly used ones.

Block Planes

The smallest and most practical plane for young woodworkers, the block plane is about 12 cm long. It is small enough to be carried in a tool box. It works well to finish work. It has a low blade angle and is often used for fine work or cutting across end grain.

It is important that planes be in proper adjustment, or they do not do a proper job. Turn the plane over and check along the bottom. The blade should appear through the gap evenly, about the thickness of a sheet of paper.

To push the plane iron out (to get more blade exposed) turn the adjusting knob clockwise. To pull the iron in, turn the knob to the left until the blade is in the correct position. Then turn it clockwise until it starts to push the plane out. The plane iron will stay in the right place when the plane is used.

To adjust for an even blade, loosen the lever cap screw. Turn the plane over and look at it. Press the plane iron to the right or left until it is even. Then tighten the lever cap screw.

Test the plane on a piece of scrap wood, not your project.

Smooth Plane

This is also a short plane, in sizes from 12 to 25 cm long. It cuts extremely smooth surfaces and stays adjusted. The smooth plane can also be used for rough planing, planing end grain, chamfers and edge shaping.

Jack Plane

This is a medium sized plane, from 30 to 75cm long, which can be used for just about any job! Because it has a longer bottom, it does less riding up and down on uneven surfaces and quickly cuts off the high spots.

Fore Plane and Jointer Plane

These planes do a good job on cutting an edge or surface perfectly straight. Fore planes are usually 45 cm long and jointer planes are usually 45 cm to 60cm long. Their long lengths allow them to ride over bumps and produce a smoothly cut surface.

SHARPENING TOOLS

Do this with adult supervision.

Whetting

Whet your chisels and plane irons on an oil stone to keep a very sharp cutting edge.

Apply oil to the stone surface to keep it moist. The oil prevents particles of steel from clogging the pores of the stone. Wipe the stone before putting it away.

Hold the chisel or plane iron on the fine grit oil stone with the bevel flat on the surface. Raise the handle slightly (5 degrees or less) so you whet only the forward part of the bevel.

Move the chisel or plane in a circular pattern back and forth lengthwise on the stone several times. Working in this way wears the stone evenly so it will last you all your life.

After you have sharpened the bevel edge, turn the blade over to remove the little bits that have appeared on the other side. Lay the blade flat on the stone. Move it back and forth a few times to remove those little bits.

Inspect the blade edge. Is it completely and evenly sharpened? Are there still some nicks or unsharpened spots? It may be necessary to repeat the whetting process until you have done a complete job.

Test your blade on a piece of wood (not your project!).

Plane marks show less if the corners of the plane iron are slightly rounded.

Round off the corners by slight honing on the whet stone.

When is it time to grind? When you notice the cutting edge is nicked or it is getting harder and harder to use the tool, it is time to grind.

Use a grind stone or an emery stone for this job. Your leader or another adult will demonstrate this.

Wear eye protection! Dip the blade in water frequently so it does not over heat. You may want to hold the blade in a clamp to hold it steady while grinding.

The plane iron or chisel should be ground to a 25 or 30 degree angle. This provides the right combination of sharpness and strength.

After grinding finish by whetting on the oil stone for a very sharp cutting edge.

WOODWORKING TIPS

- If you store your tools on a pegboard, paint the shape of the tool on the board, to help tools make their way back to the right spot!
- Magnetic strips on the workbench or on the wall nearby hold small metal tools in sight.
- Fight scratches and rust on hand tools. Store them in a drawer on a piece of carpet which has been sprayed with light machine oil.
- Help your tape measure slide smoothly! Rub it with a bit of paste wax.
- When buying a tool with a wooden handle, examine the direction of the grain of the wood. Wood grain that runs parallel to the tool head is strongest.
- A bit of beeswax or paraffin on the tip of a nail will aid in driving a nail into hardwood.
- Don't want to hit your thumb when starting a nail? Hold the nail with a pair of pliers, or else push it through a piece of cardboard or stiff paper!
- Protect the teeth on your handsaw. Slide it into a slit piece of old garden hose or a piece of styrofoam.
- Store and transport your wood chisels with their points in an old soft ball. Tennis balls work well for this.
- Does your saw blade get stuck in the kerf when sawing long pieces of wood? Prevent this by sticking a small wooden shim into the kerf after you have started the cut.
- Only use one measuring tape for a project. Sometimes the end hooks vary as much as 1/16 inch. If you must use more than one measuring tape, check them to ensure they give the same measurement.
- For precise measurements with a measuring tape, start measuring at the one cm. or one inch mark on the tape. (Sometimes the end hook has a bit of play in it.)
- To check for square in a project, measure the diagonals of the piece. They should measure exactly the same.
- Making many pieces of the same item? Use only one piece as the pattern.
- You can copy a pattern using a photocopy and an iron! Copy the picture you want. Turn the page, print down, onto the wood. Tape it so it will not shift. Heat it with an iron. Check occasionally to make sure the pattern is clear in all areas. If the pattern has words on it, first print it onto tissue paper, then turn that copy over and copy it. You will produce a copy that has the words backwards on it.
- Use old inner tubes as clamps. They will apply gentle but firm pressure onto odd shaped projects.
- Are your C clamps leaving marks on projects? Pad the clamping surfaces with felt, chair leg protectors, the caps from film canisters or small pieces of wood.
- Store glue bottles upside down, with the caps on securely! Store in a can or else make a simple holder similar to a toothbrush holder.
- Save those old toothbrushes! They work well to clean out dust or to apply stain in small areas.
- A little too heavy with the hammer? Made a few too many dents? Lift the dent by ironing a moist cloth over the dent. (Wood cells swell with the addition of water.)
- Hands all splattered with oil-based paint or stain? Soften the paint with salad oil! Then, wash with warm soap and water.
- To prevent dents from those last hammer taps, put an old tennis ball over the head of the hammer.
- Use clothes pins as mini clamps for tiny pieces of wood.
- If you lose the lid from your glue bottle, or the original one does not work well, try a mariette (the electrical wire nuts you use to twist two or more electrical wires together). The thread should hold on snugly.
- Never saw freehand. Take the time to draw a straight line!
- Put a piece of scrap wood under your project when you are drilling holes in it. This will prevent you drilling holes into the work surface.
- Always saw on the waste side of the marking line.
- Clean as you go.

- Do you plan to stain your project? Stain it before filling the nail holes, to prevent residue blemishes on the wood.
- Stain soaks deeply into end grain and makes it darker than face grain. To better match the stain, sand the end grain with a higher grit sandpaper than the face grain.
- Prevent rounding of edges by a power sander by putting another board the same thickness up against the board you are sanding. The sander will ride straight over the edge, rather than around it.
- Try styrofoam to clamp irregular shapes. The styrofoam will conform to the shape of the piece and hug it snugly without scratching.
- Hammer head slipping? Rough up the surface with a coarse emery cloth, a file or an abrasive wheel.
- Do you keep dropping screws when starting them? Try:
 1. *Chewing gum on the head (the screw's head, not yours!)*
 2. *Rubber cement on the head.*
 3. *A short piece of rubber hose on the tip of the screwdriver that is slightly bigger than the head of the screw.*
- Save some sawdust from your project to make perfectly matched wood putty. Mix the dust with white glue.
- Do your safety goggles fog up? After cleaning and drying them, put one drop of dish detergent on them and wipe dry.
- When using tools, focus on the job. If you need to talk to someone, stop work first.
- Avoid startling someone who is using tools or power equipment. Approach from the front, slowly, if possible. (Kind of like approaching a horse!)
- Never force a machine.
- Ask your leader to show you how to check to see if a machine or tool is properly grounded.
- To prevent bubbles, do not shake topcoats. Stir them gently.
- Make your own tack cloths! Moisten cheesecloth in mineral spirits. Add a teaspoon of any topcoat material (e.g. varnish) to the cheesecloth and knead it until the topcoat material is absorbed evenly. Store in a closed glass jar.
- When planing hard wood, follow the grain.
- Practice new skills on scrap wood first!
- A surface that you are going to glue should be clean and free of dust, but not sanded. Wood glues best soon after it is cut.

THINGS TO MAKE

1. Tray
2. Shadow Box
3. Chess Set
4. Paddle full size or for display only
5. Picture or Mirror Frame
6. Date Cubes
7. Set of Wooden Letters
8. Turtle Box

Tray

Make this as a practical item or decorate it to add colour to your home! This tray features rabbeted corners and a dadoed bottom for strength and appearance. Select a washable finish. The dimensions are for a standard tray. Adjust them for your needs. Optional hand holes can be cut to size.

The next time you make this tray, you could try another type of joint.

A simpler version of this tray can be made with butt joints, gluing and using fine screws to secure.

Cut List

- 1 1/4" x 20" by 13" of plywood (tray bottom)
- 2 2" x 2" x 20" sides (Wood of your choice)
- 2 2" x 3" x 12" ends (Wood of your choice)

Instructions

As with all projects, it is suggested that you sketch or make a cardboard model of this project first, before making it in wood.

1. Measure, mark and cut the pieces of wood.
2. Test assemble the pieces to check for fit.
3. Insert a 1/4" dado blade in the table saw. Set it to cut a groove 1/4" deep. Test a scrap of the wood you are using for the tray bottom in this groove. When this fits smoothly, dado the ends and sides of the tray bottom.
4. Test assemble the tray.
5. If you want to have hand holes in the ends of the tray, sketch and cut them now. Sand them smoothly.
6. Sand all the parts of the tray.
7. Glue, assemble and clamp.
8. Finish as desired.
9. Take a picture for your record book!

Shadow Box

Use this to display pictures or collections of small items. Use the type of corner joint you prefer. Or make several shadow boxes, each with a different style of joint.

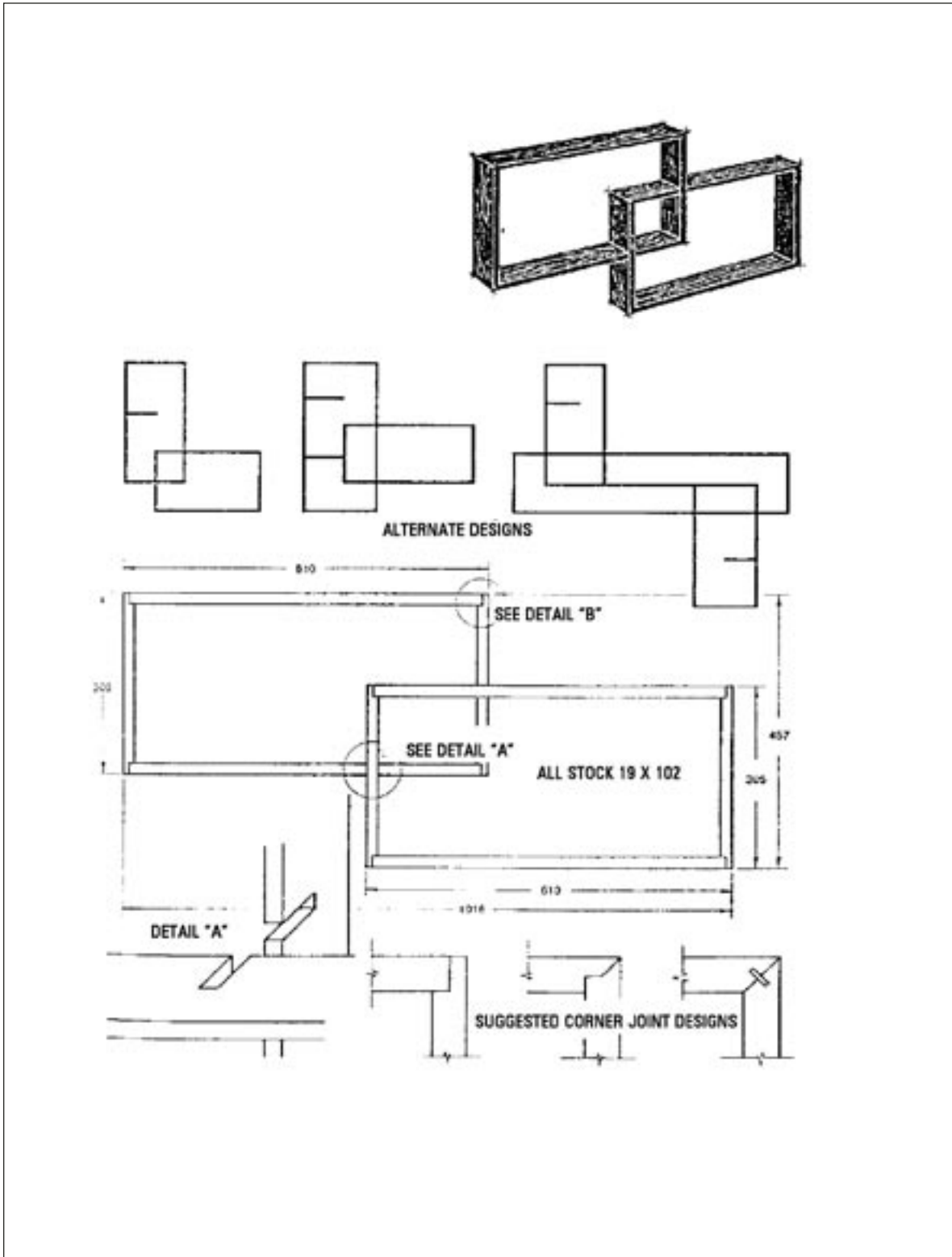

Chess Set

Make one for a special gift or one for yourself! A challenging project.

The designs for the chess pieces can easily be modified or replaced with styles you prefer. The traditional sizes for the pieces descend in this order: king, queen, bishop, knight, rook, pawn.



If you have only one colour of wood, stain half of it to provide the colour contrast needed for the two armies of pieces.

Materials for the Chess Figures

- green felt
- Hardwood
- Dark 950mm x 25mm x 25mm
- Light 950mm x 25mm x 25mm

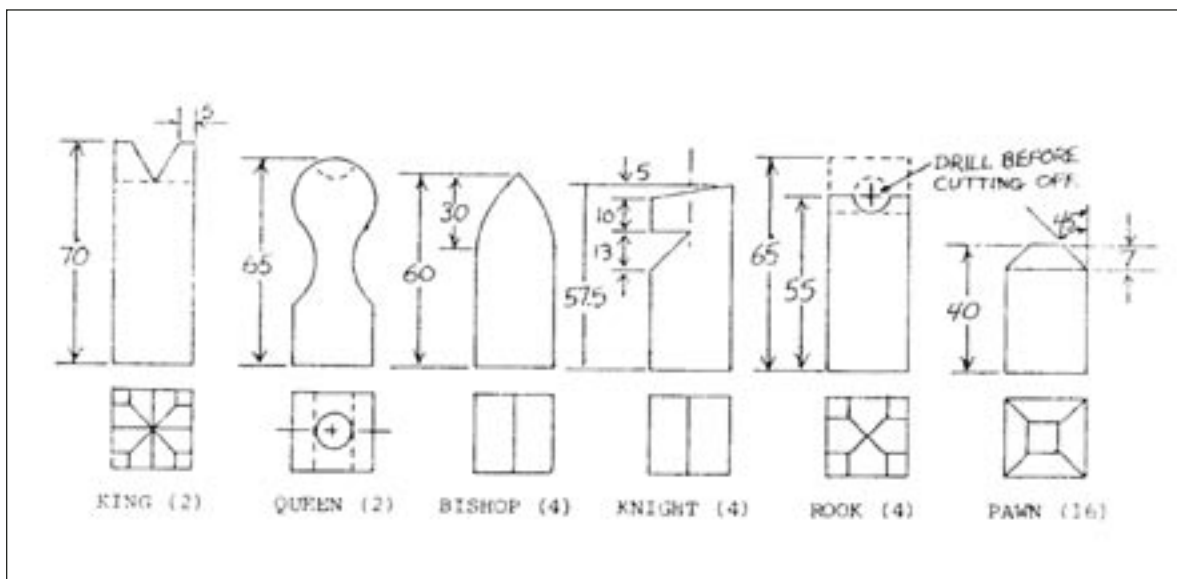

Tools

- pencil
- sanding disc
- ruler
- pencil
- try square
- marking guage
- tenon saw
- file
- chisel

Instructions

1. Mark and cut out the 16 pieces from the light wood and from the dark wood.
2. Use a sanding disc to trim the pieces to the exact length.
3. Mark out the desired design on the pieces, using a ruler, pencil, try square and marking gauge.
4. Cut with a tenon saw.
5. Shape and tidy up the cuts with a file and firmer chisel.
6. Use a sanding disc and belt sander where possible to assist in the shaping.
7. Do final sanding with glasspaper.
8. Varnish the pieces.
9. Glue green felt to the bottom of the pieces, so they do not scratch the board.

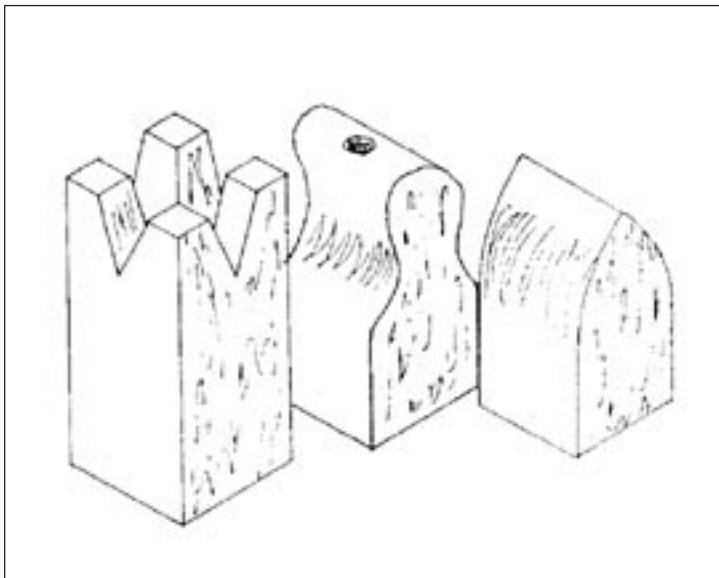

The Chess Board

Materials

- 4 strips of white wood for the board 15mm x 35mm x 350mm
- 4 strips of dark wood for the board 15mm x 35mm x 350mm
- 4 strips for frame 10mm x 25mm x 350mm

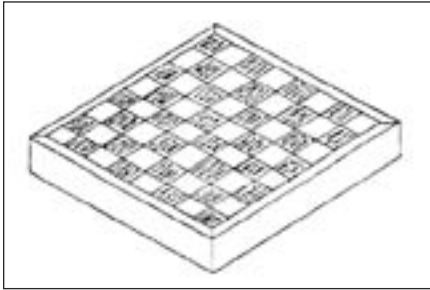

Tools

- measuring tools
- plane
- marking gauge
- table saw
- sandpapers
- nails
- nail set
- paste wax

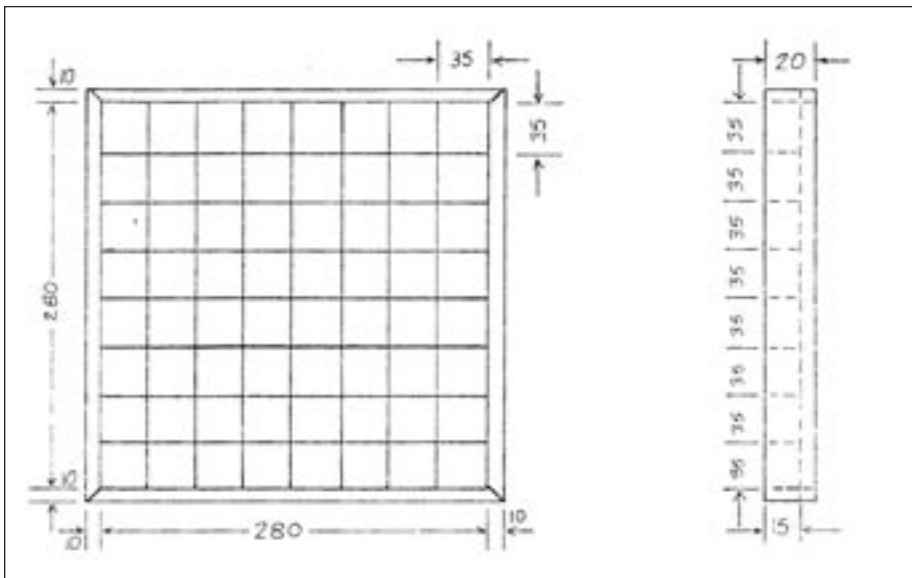

Instructions

Phase One

1. The strips are longer than the finished board, to allow for error and sanding
2. Lay the strips for the board side by side, alternating dark and light woods. Watch the direction of grains, so the pattern will be most pleasing.

3. Glue the inside edges of each strip and clamp tightly, using pipe clamps. Make sure all pieces remain level and even at one end. If you notice them buckling, unclamp, flatten them down, then reclamp. Do not rush this stage!
4. Allow to dry for 24 hours.

Phase Two

1. Recut the board into 35mm strips, across the coloured strips of glued wood.
2. Lay the strips out in a chess board pattern. Match the corners perfectly.
3. Glue and clamp.
4. Allow to dry for 24 hours.

Phase Three

1. Plane one side flat and smooth. Do not remove any more wood than is necessary.
2. Mark the board to thickness using a marking gauge.
3. Plane the board to thickness.
4. Plane the edges smooth and 90 degrees to the best side.
5. Measure board to length (check the numbers of squares required!).
6. After triple checking, cut off the extra length of board.
7. Sand all sides and edges flat and smooth using increasingly finer grades of sandpaper.
8. Measure and cut your frame strips.
9. Fit frame strips to the board using mitred corners.
10. Nail the frame to the board. Set and fill the nail holes.
11. Sand all surfaces.
12. Varnish. Let dry 24 hours.
13. Sand with 400 wet/dry sandpaper.
14. Apply second coat of varnish.
15. Sand lightly with 400 wet/dry sandpaper.
16. Apply two coats of paste wax allow 20 minutes between coats. Polish.
17. Invite someone over for a game of chess!

Paddle

You can make this project from hardwood or softwood. With hardwoods, you will be able to achieve a thinner blade. Woods that work well for a paddle include spruce, cherry, maple, pine, butternut and ash. Some people like to use a combination of woods in a paddle, especially if it is to be displayed.

The correct size for a personal paddle? If you can rest your chin on it while standing, it is the correct length for you. The instructions given are for a generic paddle, made of fir. This paddle is good for both lake and river use. The Lee Valley Tools web site gives instructions on making a marking jig which helps in marking the shape you would like in your paddle shaft. Visit www.leevalley.com.

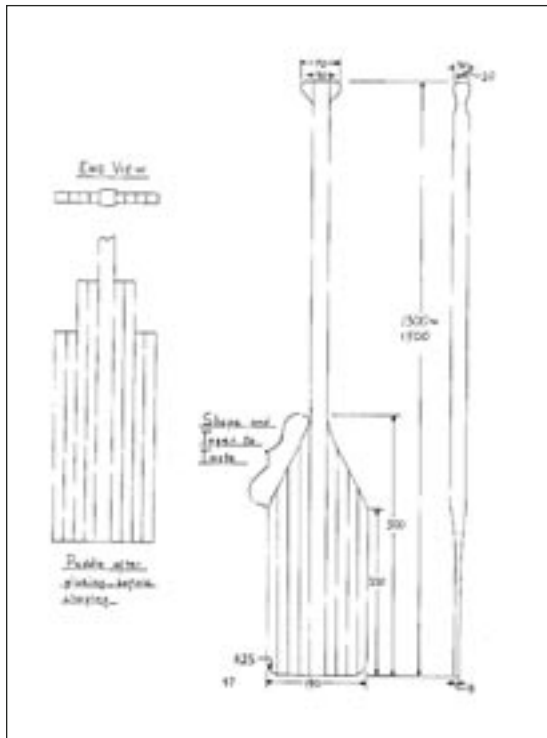

Materials

- 1 30mm x 30mm x 1500mm
- 4 20mm x 20mm x 550mm
- 4 20mm x 15mm x 450mm
- 2 30mm x 30mm x 100mm
- waterproof glue (titebond II)
- sandpaper
- marine varnish or urethane

Tools

- table saw
- jigsaw
- rasps
- clamps
- planes

Instructions

1. Make sure that the main shaft piece (the longest one) is straight, true and without flaws.
2. Glue 2 – 20mm x 20mm x 550mm pieces directly onto each side of the main shaft with ends flush. Clamp well and let dry.
3. Glue 2 – 15mm x 20mm x 450mm to the sides of the pieces you glued on in step 2. Clamp and let dry.
4. Glue the 2 – 30mm x 30mm x 100mm pieces to opposite sides of the handle end of the paddle. Clamp and let dry.
5. Pencil the outline of the blade shape on the paddle. Pencil the desired handle shape on the handle. If you already have a paddle you like, you could use it as a pattern.
6. Bandsaw or jigsaw the shape.
7. Using rasps and planes, shape and taper the blade to about 8mm on the edges and tip. The middle of the blade should remain a bit thicker, about 12mm (for strength). The blade should thicken a bit as it reaches the shaft.
8. Round the shaft until it feels comfortable in your hands.
9. Shape and taper the handle so it comfortably fits your hand. A bad fit to your hand can cause blisters. Blisters are not fun on a canoe trip.
10. Sand smooth. Remove dust. If you wish, you can put some kind of identification mark somewhere on your paddle at this time (initials, phone number etc. It's optional, but a good idea.)
11. Apply three coats of marine varnish or urethane.
12. Ask someone to take a picture of you with your new paddle. Congratulations! Long may your paddle sing.

Alternative

You may also paint the paddle with exterior grade paint. You can also paint or burn a design into the paddle, then varnish over it for protection.



Picture or Mirror Frame

You can make this to any dimensions, of course. Varnish the frame, if you wish to show off the grain. Paint it, if you want to emphasize what the frame will hold. Or leave it unfinished, if you are using a material such as old barn board! The choice is yours.

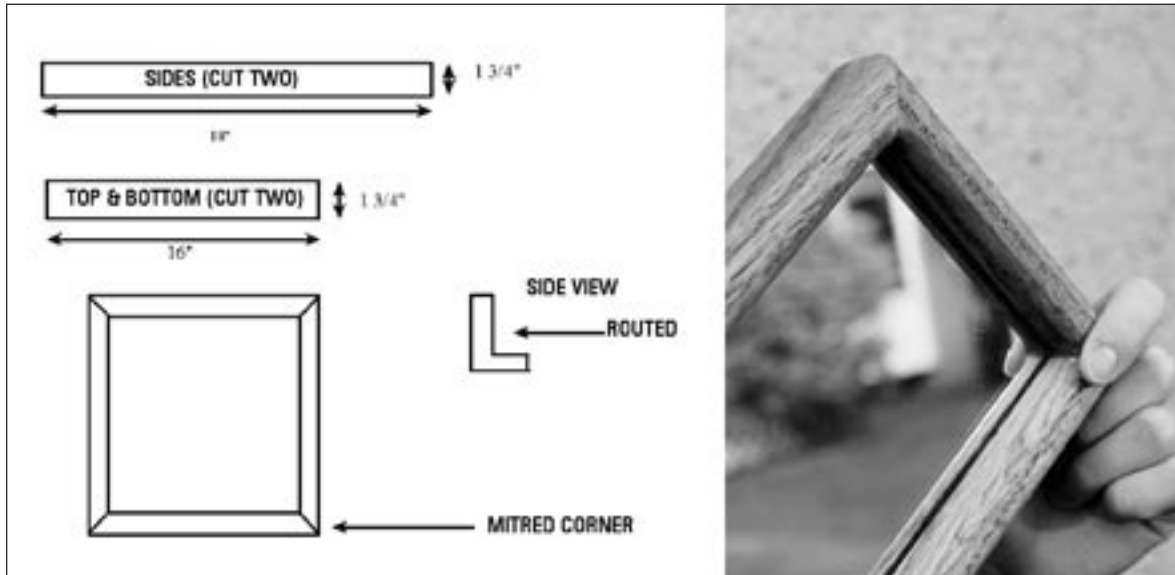

Materials

- wood of your choice
- glue
- thin panel pins (optional)
- glass or mirror cut to fit (have this cut after you have made the frame!)
- matting for picture (optional, but recommended)
- small screws and wire for hanging
- small scraps of felt

Tools

- mitre box and saw
- router
- sander
- saw

Cut List

- 2 1 3/4" x 1 3/4" x 18" (sides)
- 2 1 3/4" x 1 3/4" x 16" (top and bottom)
- 1 piece of thin board to fit within the finished back (measure and cut to fit finished frame)

Instructions to make a 18" by 16" frame.

1. Cut wood, using a mitre saw and box. Cut at a 45 degree angle. Take great care to avoid splinters.
2. Test assemble the pieces, to make sure everything will fit together snugly.
3. On the back side of each piece, rout out a groove on the inside of each piece. This will form a ledge that the picture or mirror will rest on.

If you are routing hard wood, it may take more than one pass to make the depth of ledge you want. Do not force your router.

4. Glue and clamp the four pieces together. Lay on a flat surface. Let dry overnight. It might be a good idea to put a clean piece of paper or cardboard over top, with a bit of weight, to hold things flat as they dry.
5. If you want extra reinforcement, use very thin panel pins to nail the pieces together.
6. Have the glass or mirror cut now to fit the finished product. Insert the glass or mirror into the frame. Secure it with fine panel pins.



7. Attach picture wire frame between small screws.
8. Glue small pieces of felt to bottom corner of frame so it will not mar the wall.

Tip: To avoid tilting pictures, hang frames from two, not single hooks on the wall.

Date Cubes

This project requires you to make two identical cubes from hardwood. With only two cubes you will be able to display all the days of the month. This project calls for a steady hand with a router. You can make the cubes with scraps of hardwood.

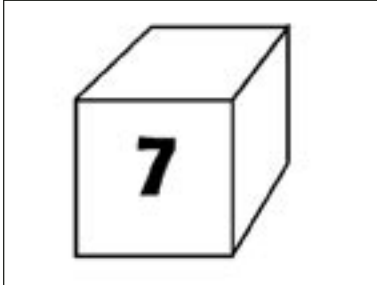

Materials

- enough hardwood to make two cubes the size that you want
- glue

Tools

- table saw
- square
- measuring tools
- hobby knife or carbon paper to transfer patterns
- pencil
- disc sander
- sandpaper
- clamps
- router
- if starting with rough lumber, you will need access to a joiner or a planer
- patterns for numbers

Instructions

1. First, practice on scrap wood making numbers using the router tip you plan to use for the numbers. This step will help you decide how big you should make your cubes. Anything smaller than two inches would be very difficult to work with, or to read.
2. If you are starting with rough lumber, smooth it so that it will glue together perfectly.
3. Measure, cut, glue and clamp your two cubes of hardwood. Take care to line up the grain in a way that you find pleasing.
4. Use the disc sander to smooth all surfaces. Make sure that all sides are square to each other and have the same dimension.
5. Print a style of number that you like (the simpler the better for a first try) using a computer. Trace or cut the pattern into the wood. The cut outline of the numbers will guide you when you are routing.
6. On one cube you will rout these numbers : 0, 1, 2, 3, 4, 5. On the other cube, make these numbers: 0, 1, 2, 6, 7, 8. (One "6" will serve also as a "9".)
7. Sand the routed cubes, using increasingly finer sandpapers. Finish with your preferred finishes.
8. Take a picture for your record book! Congratulations!

The numbers on the cubes can also be painted or burned in using wood burning tools.

Wooden Letters

This is a good way to practice using a band saw, jigsaw or scroll saw. You could make a set of letters as a gift for a child, for a local school or Sunday School. You could also make separate letters that spell out a name or messages, which could be used at home or on a shelf at school or at a Seniors' Centre. E.g. Happy Birthday! Joy! Congratulations! Welcome! Etc.



Materials

- plywood or hardwood (how thick will the wood need to be, so that the letters will stand up easily?)
- paint or stain – if these are to be used by a young child, select a child safe finish
- patterns for letters

Tools

- band saw or jig saw or scroll saw
- sandpaper
- paintbrush
- ruler

Instructions

1. Mark the letters you are going to cut out on the wood, using either a pattern or by drawing freehand.
2. Cut out the letters. With letters that have an interior opening drill a hole first, then use an appropriate saw.
3. Sand carefully, working to avoid splintering the wood.
4. Finish, using a child-friendly paint.
5. Take a picture for your record book or e-mail it to us! Congratulations!

Business Card Holder

Makes a great gift. Also a great item for bazaars or fundraisers! Very simple, useful item which requires careful use of band saw, orbital sander and router. It uses up those scraps of hardwood!



This would be a very nice thank you gift for sponsors, guest speakers or judges!

Make one long holder, rout the channel out, then cut to desired width. If you try to make just one, it is too tricky to rout out the channel.

Materials

- 1 scrap of hardwood, 1" thick
- finishing supplies
- sandpaper

Tools

- Band saw
- Router

Instructions

1. Cut a strip of hardwood about 2" wide and slightly longer than three business cards are wide.
2. Secure the wood. Using a 1/2" bit, cut a 2" deep channel in the top. The business cards will sit in this channel.
3. Sand and finish.

Turtle Box

This is a clever container made of a 2" x 4"!



Materials

- 1 2 x 4 x 24"
- glue
- sandpaper
- varnish or other finish of your choice

Tools

- joiner or planer
- clamps
- band or scroll saw
- pencil
- disc sander

Instructions

1. Run the 2 x 4 through the joiner or planer to get completely smooth surfaces.
2. Cut the 2x4 into three equal lengths (approximately 8" each).
3. Glue one piece of 2 x 4 on top of another. Clamp and let dry.
4. Glue the third piece of 2 x 4 to the top of the other two. Clamp and let dry.
5. Draw the pattern of the turtle on the top of the glued wood (on the side with no seams).
6. Use a band saw or scroll saw to cut out the turtle.
7. Cut a 1/4" layer of turtle off both sides. You will have two thin turtle shapes and one thick one.
8. Trace the drawer pattern on the thick turtle.
9. Use the band saw to cut out the drawer.
10. Use the band saw to cut a 1/4" layer off both sides of the drawer. You will end up with two thin drawer pieces and one thick one.

11. Trace the drawer cavity on the thick piece of drawer.
12. Use the band saw to cut out the drawer cavity out of the thick piece of drawer.
13. Glue the thin drawer pieces to the thick drawer piece, to make a complete drawer! Test to make sure it will go into the turtle. Clamp and let dry.
14. Glue the thin turtle pieces to the thick turtle pieces to make a turtle. Clamp and let dry.
15. Sand to remove all traces of glue and to smooth the surfaces.
16. Stain and varnish the way you would like.
17. Take a picture for your record book!

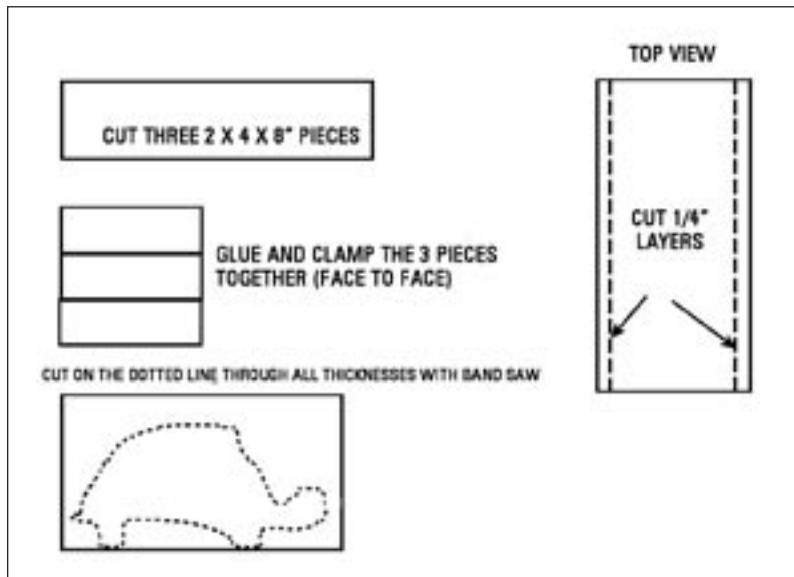

MEMBERS: I CAN CHECKLIST

Leader Signature

Safety

- Meet all safety objective of levels one and two _____
- Identify and deal appropriately with shop hazards - physical, mechanical, chemical, electrical and human _____
- Encourage safe behaviour in other people _____
- Show leadership by working and playing safely _____
- Teach safe procedures to other members _____
- Select personal protective devices according to task at hand _____
- Determine if safety shields are in place by visual inspection _____
- Locate shut offs for power tools _____
- Operate shut offs _____

The Forestry Industry

- Identify forestry as one of Alberta's major industries and employers _____
- Trace the route of wood products from wood lot to consumer _____
- Name at least five careers linked to forestry and the preparation for that career _____
- List sources of information on the forestry industry _____

Drafting, Drawing & Dimensioning

- Produce, read and interpret isometric and orthographic drawings _____
- Translate drawings into projects _____
- Identify/determine degree of difficulty of a project from a drawing _____
- Plan order of work from a drawing _____
- Plan layout of pattern on wood, to get best use of wood _____
- Label drawing accurately and clearly according to standard woodworking procedures _____
- Take accurate measurements _____

Joinery

- Identify at least three different joints and explain how they are made _____
- Identify tools used for specific joints _____
- Construct a project using a new type of joint _____
- Select jointing techniques according to strength, appearance _____
- Glue and clamp a joint for maximum strength and best appearance _____

Super Power Tools

- May include the following: Router, Band Saw, Radial Arm Saw, Drill Press, Stationery Belt Sander, Bench Grinder, Table Saw. _____
- Identify tools accurately _____
- Explain purpose of each tool _____
- Explain and demonstrate the use of each tool _____
- Explain safety precautions for each tool _____
- Compare various models _____
- Demonstrate safe use of tools _____
- Ask for help if unsure _____
- Ask another member to stop if I see unsafe practices or hazards. _____

Gluing & Clamping

- Identify at least three types of clamps _____
- Demonstrate how to use those clamps _____
- Show how to avoid clamping scars on a project _____
- Determine the correct amount of pressure when clamping a glued joint _____
- Name three types of glue used in woodworking, their respective properties and the best use of each _____

Additional Hand Tools

- Identify block plane and jack plane and demonstrate their use
- Demonstrate inspection and care of a plane
- Assess need for blade adjustment
- Accurately and safely set the blade in a plane
- Use a plane to smooth wood
- Explain the value of maintaining tools in good order

Sharpening Tools

- Determine when a tool needs to be sharpened
- Name the equipment and supplies to be used in sharpening
- Observe safe procedures when sharpening tools
- Sharpen chisels and plane irons
- Test for the quality of a sharpening job
- Explain how to use and store tools to prevent damage and excessive wear
- Explain dressing of a grindstone - what, why, how and when

EVALUATION

Your input is a valuable asset to the 4-H program!

As you go through the project year, write your comments and suggestions about the project on this form. When you complete your project, mail this form to us. We want to hear from you!

Woodworking Project Evaluation

Evaluation Date: _____

Please Tell Us

Which techniques and skills did you learn and use for this project?

What did you like best about completing this project?

Are you pleased with your project? Is there anything you would change if you were to do the project again?

What are you going to do with your project?

How long did it take you to finish your project?

Additional Comments?
